

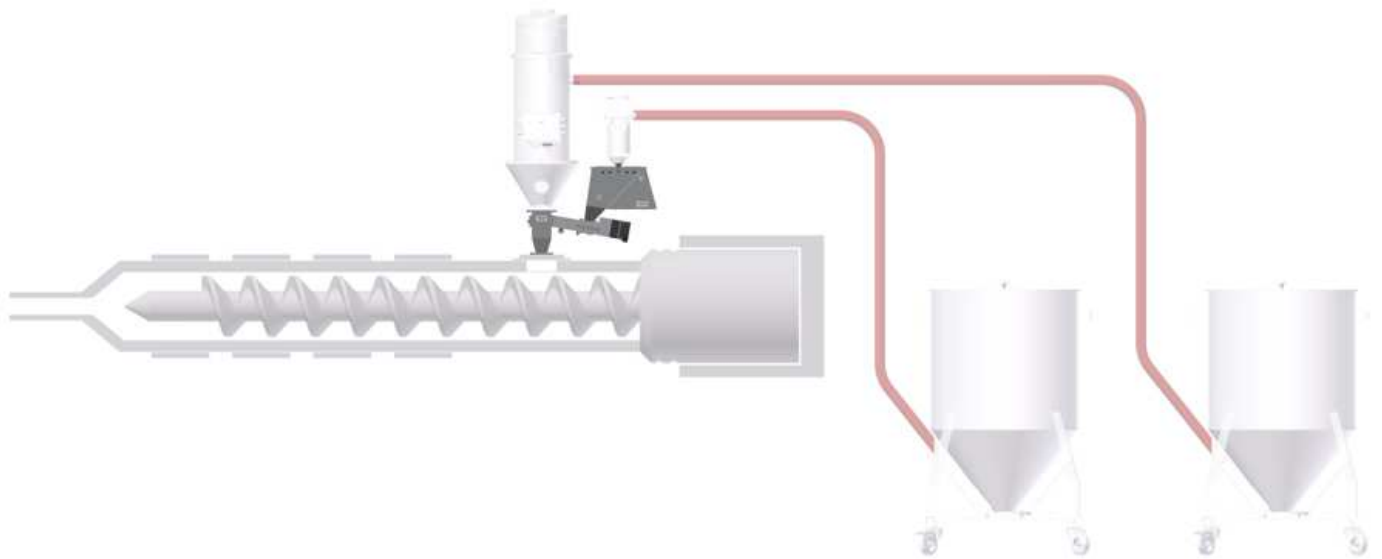

DV1mix series

NEW OMAP
never stop innovating

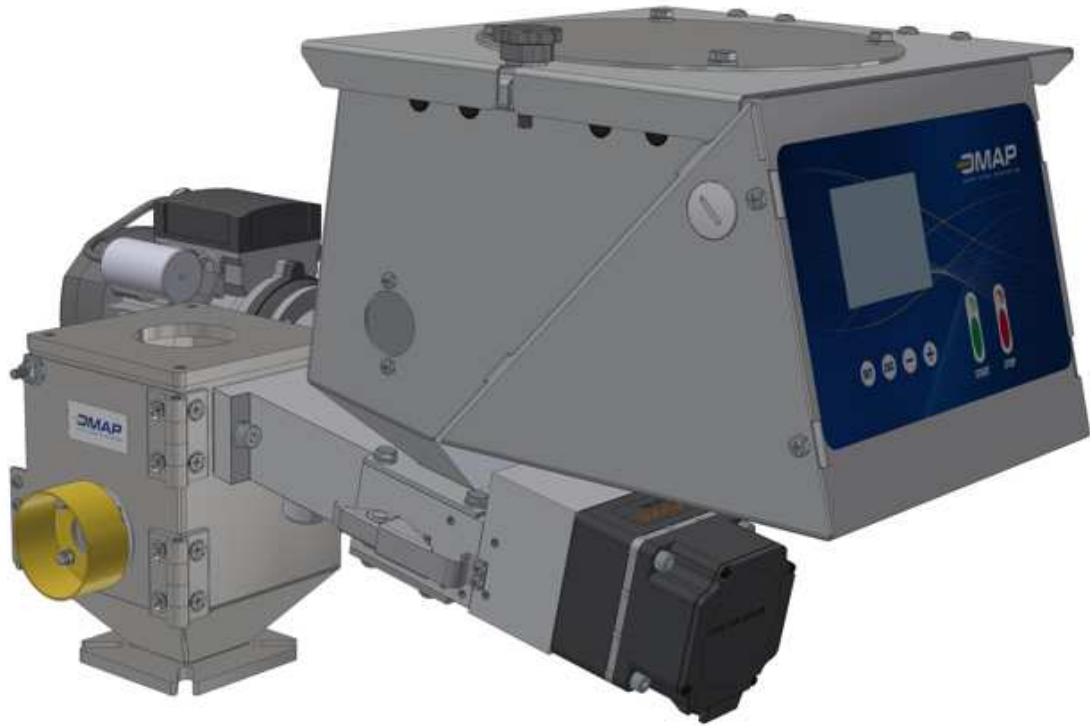



DV1mix		DV1mix50	DV1mix20
Campo produzione <i>Throughput range</i>	kg/h	0,2 ÷ 3,5	0,4 ÷ 7,0
Coclea (D x passo) <i>Screw (D x pitch)</i>	mm	16 x 12	16 x 12
Volume tramoggia <i>Hopper volume</i>	dm ³	6	6
Potenza motore <i>Motor power</i>	W	50	50
Velocità motore <i>Motor speed</i>	rpm	2500	2500
Velocità max coclea <i>Max Screw Speed</i>	rpm	50	125
Rapporto trasmissione <i>Gear box ratio DV</i>	-	1:50	1:20
Tensione <i>Voltage</i>	-	230V/1/50Hz	230V/1/50Hz
Potenza MIX <i>MIX Power</i>	kW	0,18	0,18
Rapporto trasmissione MIX <i>Gear box ratio MIX</i>	-	1:100	1:100
Velocità MIX <i>MIX speed</i>	rpm	14	14

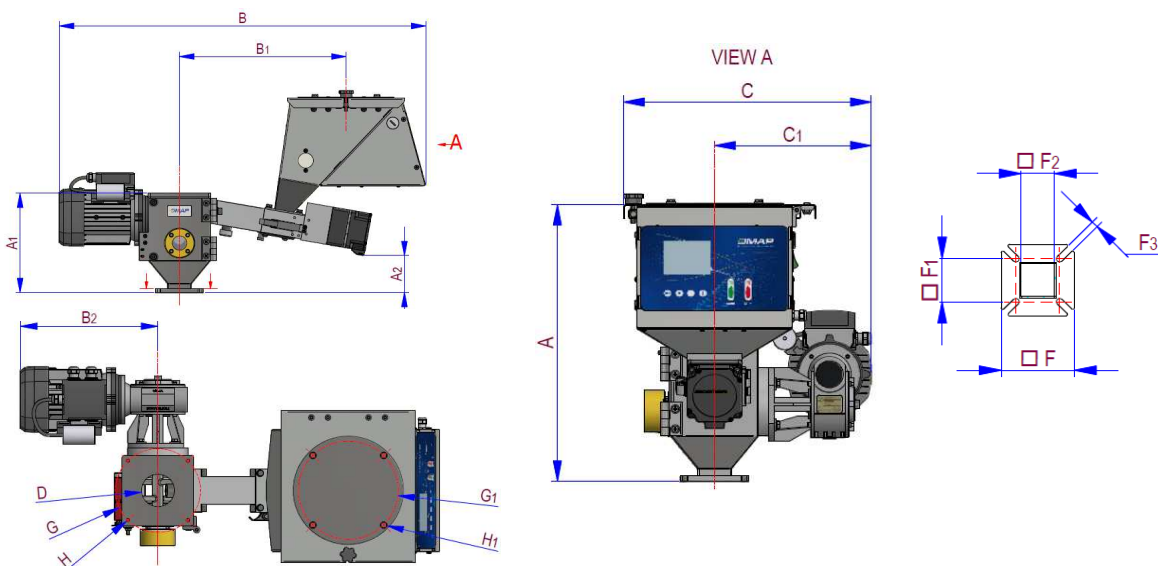

DV1mix		DV1mix50	DV1mix20
A	mm	410	410
A1	mm	210	210
A2	mm	78	78
B	mm	762	762
B1	mm	346	346
B2	mm	250	250
C	mm	362	362
C1	mm	230	230
D (∅)	mm	60	60
F	mm	100 x 100	100 x 100
F1	mm	60 x 60	60 x 60
F2	mm	45 x 45	45 x 45
F3	mm	9	9
G (∅)	mm	155	155
G1 (∅)	mm	182	182
H (M)	-	8	8
H1 (M)	-	6	6